



### Product Summary

$V_{(BR)DSS}$	$R_{DS(on)TYP}$	$I_D$
30V	11mΩ@10V	25A
	15mΩ@4.5V	
-30V	28mΩ@-10V	-16A
	39mΩ@-4.5V	

### Feature

- Trench Technology Power MOSFET
- Low  $R_{DS(ON)}$
- Low Gate Charge
- Low Gate Resistance

### Application

- Load Switch
- DC/DC Converter

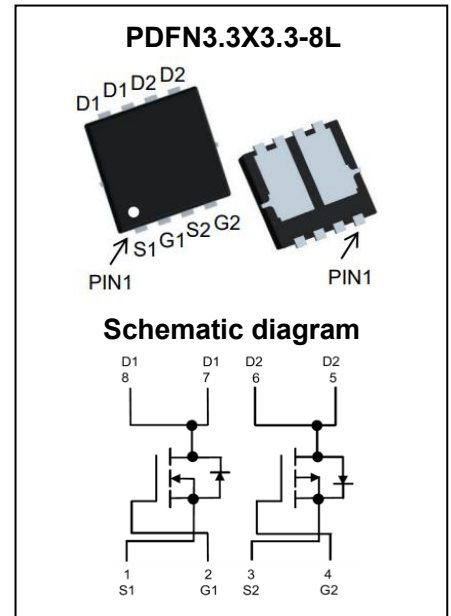

### MARKING:



M280NP03L = Device Code  
 XX = Data Code  
 Solid Dot = Green Device Indicator

### ABSOLUTE MAXIMUM RATINGS ( $T_A = 25^\circ\text{C}$ unless otherwise noted)

Parameter	Symbol	NMOS	PMOS	Unit	
Drain - Source Voltage	$V_{DS}$	30	-30	V	
Gate - Source Voltage	$V_{GS}$	$\pm 20$	$\pm 20$	V	
Continuous Drain Current <sup>1</sup>	$I_D$	$T_C = 25^\circ\text{C}$	25	-16	A
		$T_C = 100^\circ\text{C}$	16	-10	
Pulsed Drain Current <sup>2</sup>	$I_{DM}$	100	-64	A	
Single Pulsed Avalanche Current <sup>3,4</sup>	$I_{AS}$	14	-15	A	
Single Pulsed Avalanche Energy <sup>3,4</sup>	$E_{AS}$	49	56	mJ	
Power Dissipation <sup>6</sup>	$P_D$	17	15	W	
Thermal Resistance from Junction to Ambient <sup>7</sup>	$R_{\theta JA}$	58	70	$^\circ\text{C/W}$	
Thermal Resistance from Junction to Case	$R_{\theta JC}$	7.4	8.3	$^\circ\text{C/W}$	
Junction Temperature	$T_J$	150	150	$^\circ\text{C}$	
Storage Temperature	$T_{STG}$	-55~ +150	-55~ +150	$^\circ\text{C}$	

## MOSFET ELECTRICAL CHARACTERISTICS ( $T_A = 25^\circ\text{C}$ unless otherwise noted)

### NMOS:

Parameter	Symbol	Test Condition	Min	Type	Max	Unit
<b>Off Characteristics</b>						
Drain - Source Breakdown Voltage	$V_{(BR)DSS}$	$V_{GS} = 0V, I_D = 250\mu A$	30			V
Zero Gate Voltage Drain Current	$I_{DSS}$	$V_{DS} = 30V, V_{GS} = 0V$			1	$\mu A$
Gate - Body Leakage Current	$I_{GSS}$	$V_{GS} = \pm 20V, V_{DS} = 0V$			$\pm 100$	nA
<b>On Characteristics<sup>3</sup></b>						
Gate Threshold Voltage	$V_{GS(th)}$	$V_{DS} = V_{GS}, I_D = 250\mu A$	1.0	1.5	2.5	V
Drain-Source On-Resistance	$R_{DS(on)}$	$V_{GS} = 10V, I_D = 6A$		11	15	m $\Omega$
		$V_{GS} = 4.5V, I_D = 6A$		15	23	
<b>Dynamic Characteristics</b>						
Input Capacitance	$C_{iss}$	$V_{DS} = 15V, V_{GS} = 0V, f = 1MHz$		870		pF
Output Capacitance	$C_{oss}$			114		
Reverse Transfer Capacitance	$C_{rss}$			91		
Gate Resistance	$R_g$	$V_{DS} = 0V, V_{GS} = 0V, f = 1MHz$		3.6		$\Omega$
<b>Switching Characteristics</b>						
Total Gate Charge	$Q_g$	$V_{DS} = 15V, V_{GS} = 10V, I_D = 6A$		18		nC
Gate-Source Charge	$Q_{gs}$			2.3		
Gate-Drain Charge	$Q_{gd}$			3.9		
Turn-On Delay Time	$t_{d(on)}$	$V_{DD} = 15V, V_{GS} = 10V, I_D = 20A,$ $R_G = 3\Omega$		6		ns
Turn-On Rise Time	$t_r$			56		
Turn-Off Delay Time	$t_{d(off)}$			17		
Turn-Off Fall Time	$t_f$			8		
<b>Source - Drain Diode Characteristics</b>						
Diode Forward Voltage <sup>3</sup>	$V_{SD}$	$V_{GS} = 0V, I_S = 1A$			1.2	V

**PMOS:**

Parameter	Symbol	Test Condition	Min	Type	Max	Unit
<b>Off Characteristics</b>						
Drain - Source Breakdown Voltage	$V_{(BR)DSS}$	$V_{GS} = 0V, I_D = -250\mu A$	-30			V
Zero Gate Voltage Drain Current	$I_{DSS}$	$V_{DS} = -30V, V_{GS} = 0V$			-1	$\mu A$
Gate - Body Leakage Current	$I_{GSS}$	$V_{GS} = \pm 20V, V_{DS} = 0V$			$\pm 100$	nA
<b>On Characteristics<sup>3</sup></b>						
Gate Threshold Voltage	$V_{GS(th)}$	$V_{DS} = V_{GS}, I_D = -250\mu A$	-1.0	-1.5	-2.5	V
Drain-Source On-Resistance	$R_{DS(on)}$	$V_{GS} = -10V, I_D = -5A$		28	36	m $\Omega$
		$V_{GS} = -4.5V, I_D = -5A$		39	60	
<b>Dynamic Characteristics</b>						
Input Capacitance	$C_{iss}$	$V_{DS} = -15V, V_{GS} = 0V, f = 1MHz$		1016		pF
Output Capacitance	$C_{oss}$			119		
Reverse Transfer Capacitance	$C_{rss}$			102		
Gate Resistance	$R_g$	$V_{DS} = 0V, V_{GS} = 0V, f = 1MHz$		18		$\Omega$
<b>Switching Characteristics</b>						
Total Gate Charge	$Q_g$	$V_{DS} = -15V, V_{GS} = -10V, I_D = -5A$		21		pC
Gate-Source Charge	$Q_{gs}$			2.8		
Gate-Drain Charge	$Q_{gd}$			4.5		
Turn-On Delay Time	$t_{d(on)}$	$V_{DD} = -15V, V_{GS} = -10V, I_D = 15A,$ $R_G = 2.7\Omega$		6		ns
Turn-On Rise Time	$t_r$			45		
Turn-Off Delay Time	$t_{d(off)}$			27		
Turn-Off Fall Time	$t_f$			20		
<b>Source - Drain Diode Characteristics</b>						
Diode Forward Voltage <sup>3</sup>	$V_{SD}$	$V_{GS} = 0V, I_S = -1A$			-1.2	V

**Notes :**

- The maximum current rating is limited by package. And device mounted on a large heatsink
- Pulse Test : Pulse Width  $\leq 10\mu s$ , duty cycle  $\leq 1\%$ .
- $E_{AS}$  condition:  $V_{DD} = 15V, V_{GS} = 10V, L = 0.5mH, R_G = 25\Omega$  Starting  $T_J = 25^\circ C$ .
- $E_{AS}$  condition:  $V_{DD} = -15V, V_{GS} = -10V, L = 0.5mH, R_G = 25\Omega$  Starting  $T_J = 25^\circ C$ .
- Pulse Test : Pulse Width  $\leq 300\mu s$ , duty cycle  $\leq 2\%$ .
- The power dissipation  $P_D$  is limited by  $T_{J(MAX)} = 150^\circ C$ . And device mounted on a large heatsink
- Device mounted on  $1in^2$  FR-4 board with 2oz. Copper, in a still air environment with  $T_A = 25^\circ C$ .

**Typical Characteristics**

**NMOS:**

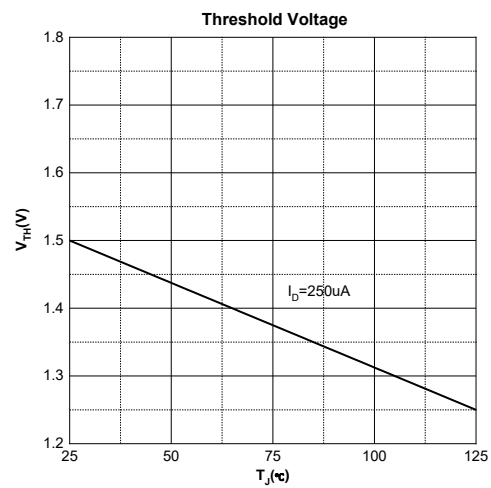
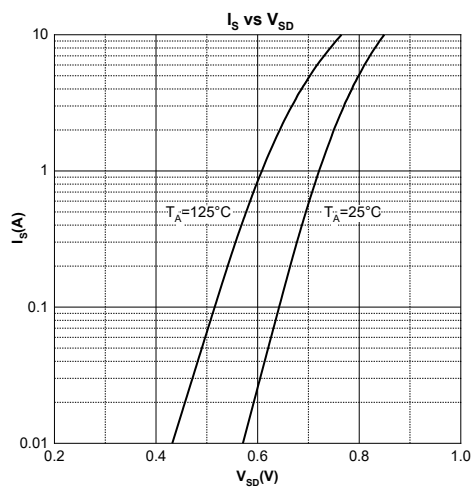
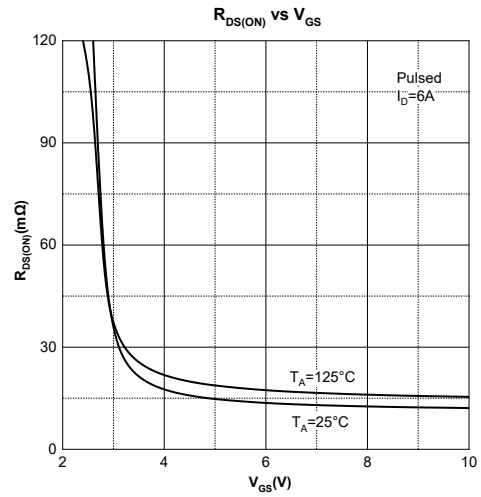
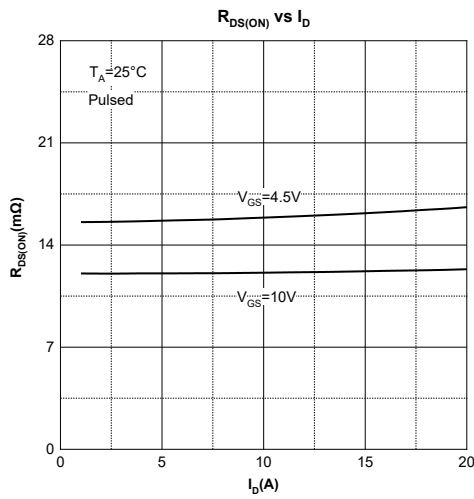
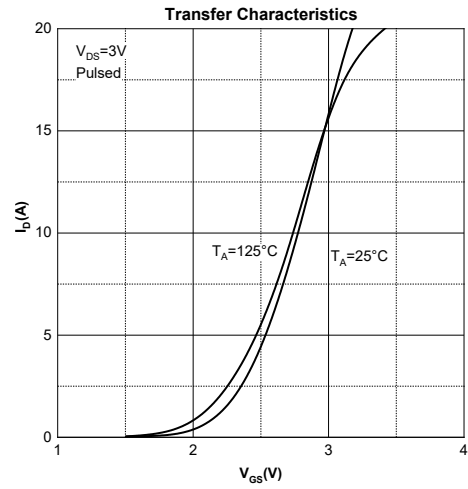
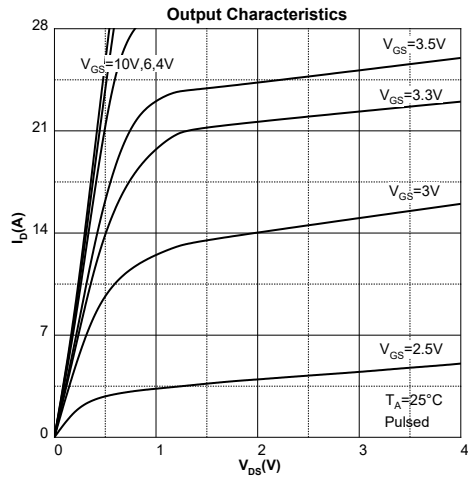

**Typical Characteristics**

**PMOS:**

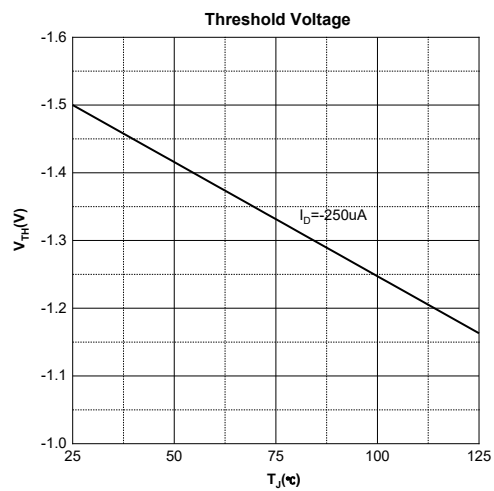
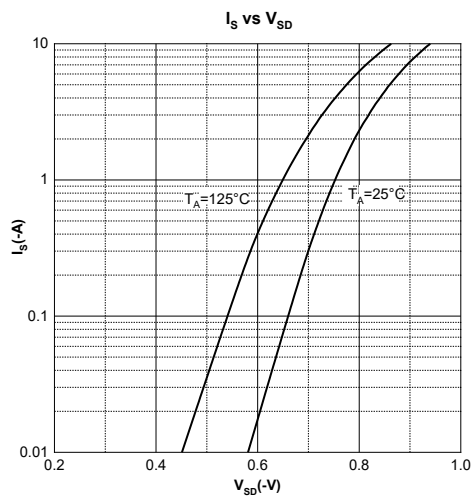
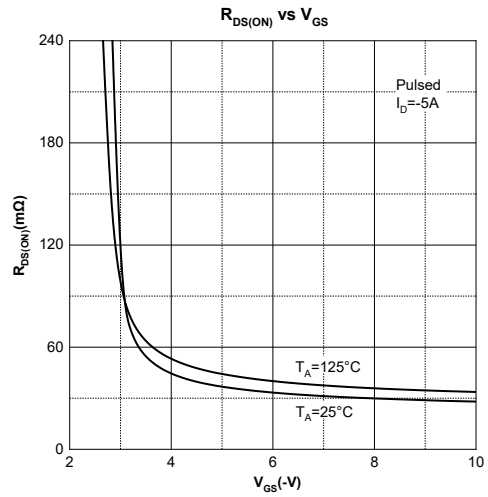
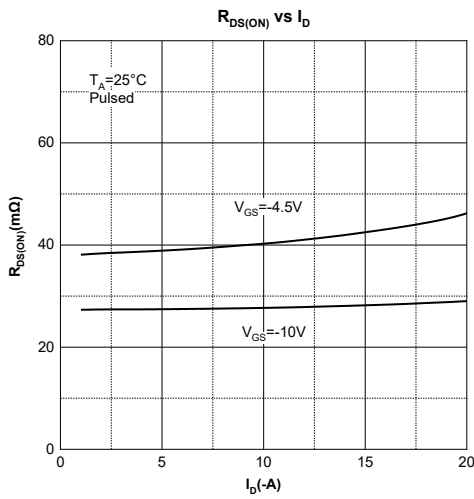
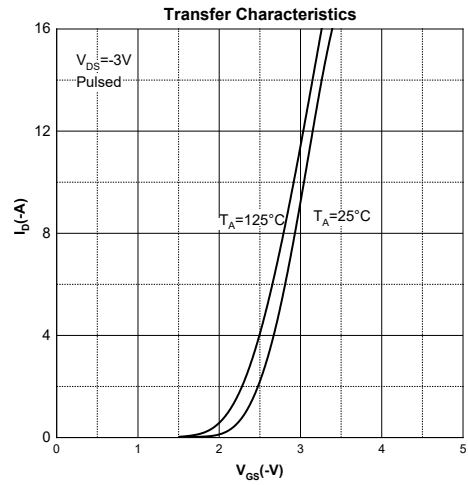
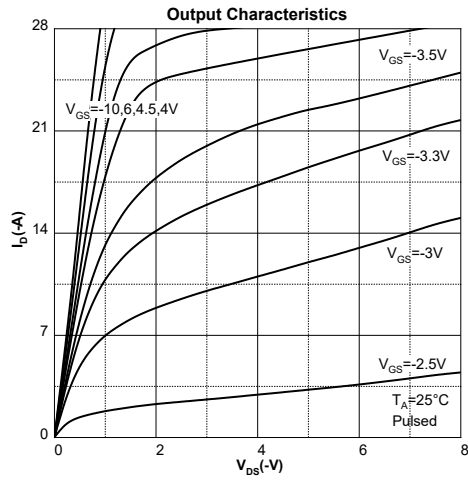

## PDFN3.3X3.3-8L Package Information

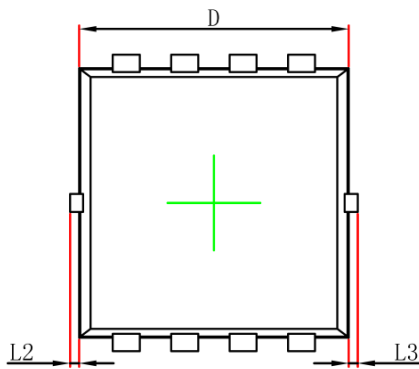

Top View  
[顶视图]

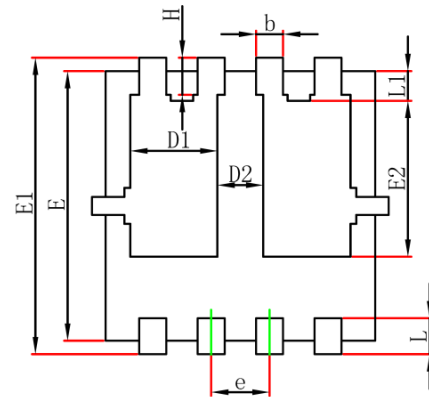

Bottom View  
[背视图]

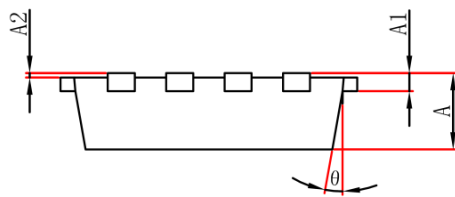

Side View  
[侧视图]

Symbol	Dimensions In Millimeters		Dimensions In Inches	
	Min.	Max.	Min.	Max.
A	0.700	0.900	0.028	0.035
A1	0.152REF		0.006REF	
A2	0.000	0.050	0.000	0.002
D	2.900	3.200	0.114	0.126
D1	0.935	1.135	0.037	0.045
D2	0.280	0.480	0.011	0.019
E	2.900	3.200	0.114	0.126
E1	3.150	3.450	0.124	0.136
E2	1.535	1.935	0.060	0.076
b	0.200	0.400	0.008	0.016
e	0.550	0.750	0.022	0.030
L	0.300	0.500	0.012	0.020
L1	0.180	0.480	0.007	0.019
L2	0.000	0.100	0.000	0.004
L3	0.000	0.100	0.000	0.004
H	0.315	0.515	0.012	0.020
θ	0°	12°	0°	12°

**Attention:**

- GreenPower Electronics reserves the right to improve product design function and reliability without notice.
- Any and all semiconductor products have certain probability to fail or malfunction, which may result in personal injury, death or property damage. Customer are solely responsible for providing adequate safe measures when design their systems.
- GreenPower Electronics products belong to consumer electronics or other civilian electronic products.